

Powermax85®

Duramax™ hand/machine torch consumables



Minimum order quantity			1	1	5	5	1
Consumable type	Torch type	Amperage	Shield/deflector	Retaining cap	Nozzle	Electrode	Swirl ring
Drag-cutting	Hand	45	220818 ²	220854	220941 ²	220842 ² or 220777 ^{1,2}	220857
		65			220819 ²		
		85			220816 ²		

¹For longer consumable life when cutting metal 1/2 inch (12 mm) and under, check out the CopperPlus electrode (part number 220777).

²Consumable available in bulk packaging. See order information below.



Minimum order quantity			1	1	5	5	1
Consumable type	Torch type	Amperage	Shield/deflector	Retaining cap	Nozzle	Electrode	Swirl ring
Mechanized	Machine	45	220817 ² or 220955 ²	220854 ² or 220953 (ohmic)	220941 ²	220842 ² or 220777 ^{1,2}	220857
		65			220819 ²		
		85			220816 ²		

¹For longer consumable life when cutting metal 1/2 inch (12 mm) and under, check out the CopperPlus electrode (part number 220777).

²Consumable available in bulk packaging. See order information below.

³Deflector for unshielded cutting.



Minimum order quantity			1	1	5	5	1
Consumable type	Torch type	Amperage	Shield/deflector	Retaining cap	Nozzle	Electrode	Swirl ring
Gouging	Hand/Machine	30-85	220798	220854	220797 ²	220842 ²	220857

²Consumable available in bulk packaging. See order information below.



Minimum order quantity			1	1	5	5	1
Consumable type	Torch type	Amperage	Shield/deflector	Retaining cap	Nozzle	Electrode	Swirl ring
FineCut®	Hand	45	220931	220854 or 220953 (ohmic)	220930 ²	220842 ²	220947
	Machine		220955 or 220948 (ohmic)				220857

²Consumable available in bulk packaging. See order information below.



Duramax consumable kits

Language combinations available		English	French/English	English/French/Italian/Spanish	Spanish/Portuguese	English/Swedish/Norwegian/Finnish	English/German/Polish/Czech
All-in-one kit	Handheld	850890	850969	850965	850970	850967	850976
	Mechanized	850880	850963	850941	850964	850961	850960
FineCut® kit	Handheld	850930	850957	850953	850968	850955	850954
	Mechanized	850920	850951	850947	850952	850949	850958

Duramax consumable bulk kits

Order quantity	25	25	25	25	25	25	25	10	10
Bulk kit part number	228934	228767	228761	228762	228765	228759	228760	228763	228764
Contents	220777 electrode	220842 electrode	220930 nozzle	220797 nozzle	220941 nozzle	220819 nozzle	220816 nozzle	220817 shield	220818 shield

See pages 50-51 for current system part number information.



Duramax™ 75° hand torch parts



Duramax 75° hand torch assembly

Item	Kit/Part number	Description
	059473	Duramax 75° hand torch assembly with 7.6 m (25') lead
	059474	Duramax 75° hand torch assembly with 15.2 m (50') lead
	059475	Duramax 75° hand torch assembly with 22.8 m (75') lead
1	228954	Kit: Duramax 75°/HRT Torch handle replacement
2	075714 ¹	Handle screws, #4 x 1/2 slotted TORX pan head, S/B
3	228721	Kit: Duramax 75°/Duramax 15°/HRT/HRTs (spring and trigger assembly)
4	228714 ¹	Kit: Duramax 75° Torch main body replacement (3/8" coupler)
4	228958 ¹	Kit: Duramax 75° Torch main body replacement (1/2" coupler)
5	058519	O-ring
6	228719	Kit: Duramax 75° Cap-sensor switch replacement
7	228959 ¹	Kit: Duramax 75° Torch lead replacement, 7.6 m (25')
7	228960 ¹	Kit: Duramax 75° Torch lead replacement, 15.2 m (50')
7	228961	Kit: Duramax 75° Torch lead replacement, 22.8 m (75')
8	228721	Trigger start switch
	223035 ²	Kit: 85 A Work lead with hand clamp, 7.6 m (25')

¹Before ordering these parts verify the date the torch was built.

²Other work lead options available.

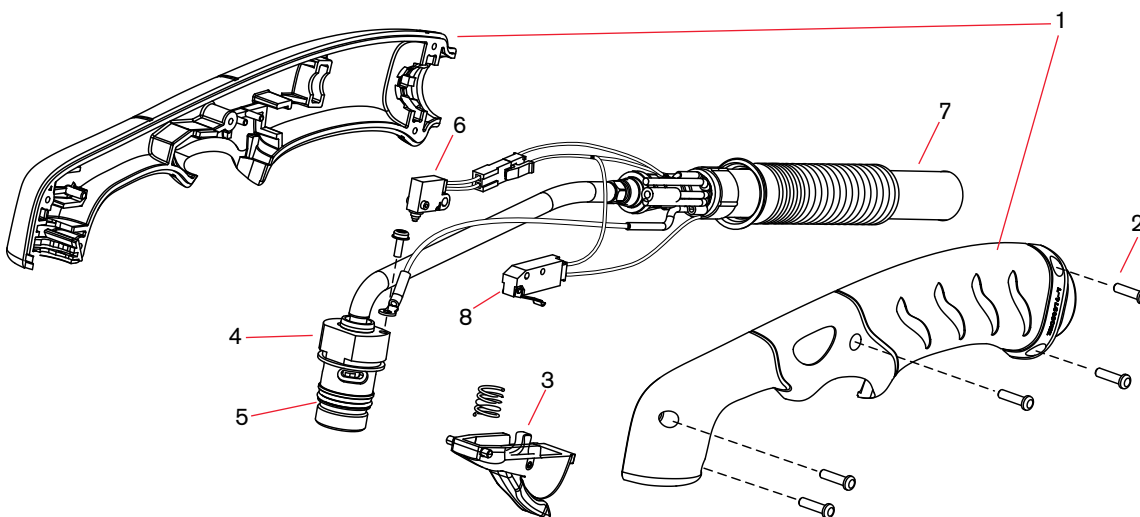

See pages 50-51 for current system part number information.

Duramax™ 15° hand torch parts



Duramax 15° hand torch assembly

Item	Kit/Part number	Description
	059470	Duramax 15° hand torch assembly with 7.6 m (25') lead
	059471	Duramax 15° hand torch assembly with 15.2 m (50') lead
	059472	Duramax 15° hand torch assembly with 22.8 m (75') lead
1	228955	Kit: Duramax 15° Torch handle replacement
2	075714 ¹	Handle screws, #4 x 1/2 slotted TORX pan head, S/B
3	228721	Kit: Duramax 15°/Duramax 75°/HRT/HRTs (spring and trigger assembly)
4	228715 ¹	Kit: Duramax 15° Torch main body replacement (3/8" coupler)
4	228957 ¹	Kit: Duramax 15° Torch main body replacement (1/2" coupler)
5	058519	O-ring
6	228109	Kit: Duramax 15° Cap-sensor switch replacement
7	228959 ¹	Kit: Duramax 15° Torch lead replacement, 7.6 m (25')
7	228960 ¹	Kit: Duramax 15° Torch lead replacement, 15.2 m (50')
7	228961	Kit: Duramax 15° Torch lead replacement, 22.8 m (75')
8	228721	Trigger start switch
	223035 ²	Kit: 85 A Work lead with hand clamp, 7.6 m (25')

¹Before ordering these parts verify the date the torch was built.

²Other work lead options available.

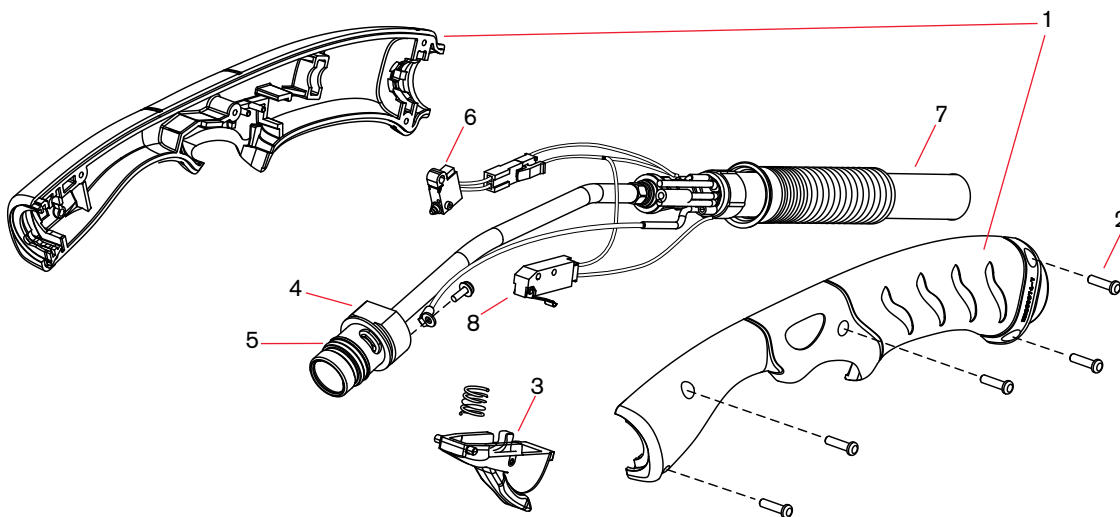

See pages 50–51 for current system part number information.

Duramax™ 180° machine torch parts



Duramax 180° machine torch assembly

Item	Kit/Part number	Description
	059476	Duramax 180° machine torch assembly with 4.5 m (15') lead
	059477	Duramax 180° machine torch assembly with 7.6 m (25') lead
	059478	Duramax 180° machine torch assembly with 10.7 m (35') lead
	059479	Duramax 180° machine torch assembly with 15.2 m (50') lead
	059480	Duramax 180° machine torch assembly with 22.8 m (75') lead
1	228737	Kit: Duramax 180° positioning sleeve
2	228738	Kit: Duramax 180° removable gear rack
3	228735	Kit: Duramax 180°/Duramax 180° torch front mounting sleeve
4	228736	Kit: Duramax 180°/Duramax 180° torch adapter ring (coupler)
5	228716	Kit: Duramax 180°/Duramax 180° torch main body replacement
6	228720	Kit: Cap-sensor switch replacement
7	058519	O-ring
8	075504	Pilot terminal screw
9	228730	Kit: Duramax 180°/Duramax 180° torch lead replacement, 4.5 m (15')
9	228731	Kit: Duramax 180°/Duramax 180° torch lead replacement, 7.6 m (25')
9	228732	Kit: Duramax 180°/Duramax 180° torch lead replacement, 10.7 m (35')
9	228733	Kit: Duramax 180°/Duramax 180° torch lead replacement, 15.2 m (50')
9	228734	Kit: Duramax 180°/Duramax 180° torch lead replacement, 22.8 m (75')
	128650	Remote start pendant for machine torch, 7.6 m (25')
	128651	Remote start pendant for machine torch, 15.2 m (50')
	128652	Remote start pendant for machine torch, 22.8 m (75')
	223035 ¹	Kit: 85 A Work lead with hand clamp, 7.6 m (25')

¹Other work lead options available.

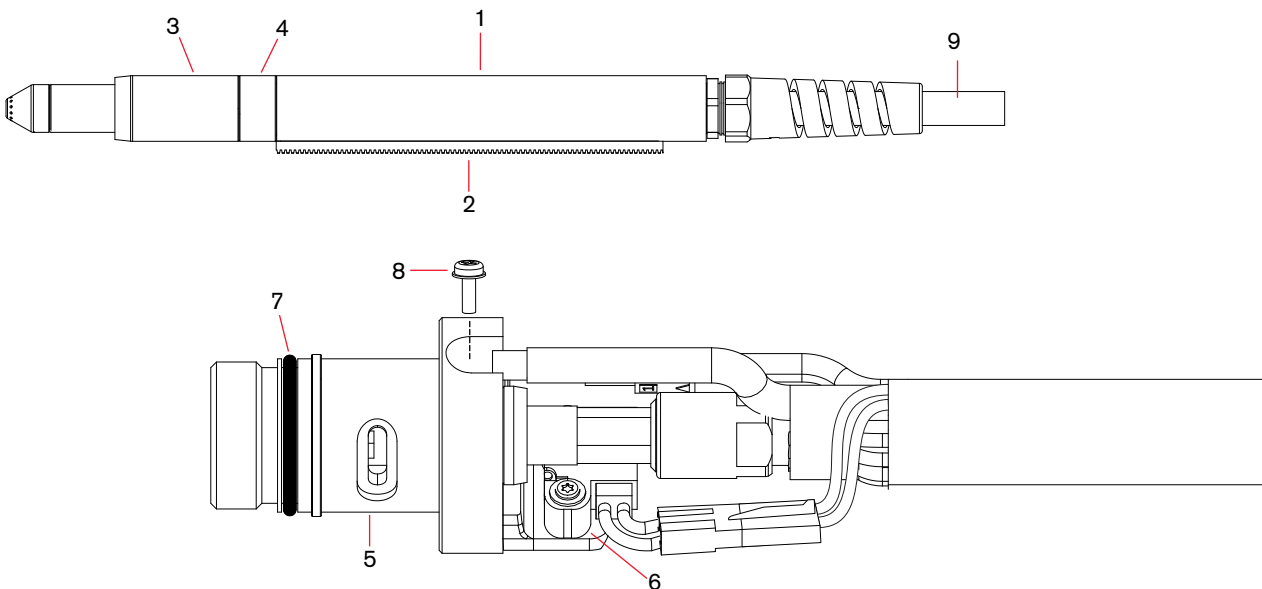

See pages 50-51 for current system part number information.

Duramax™ 180° mini machine torch parts



Duramax 180° mini machine torch assembly

Item	Kit/Part number	Description
	059481	Duramax 180° mini machine torch assembly with 4.5 m (15') lead
	059482	Duramax 180° mini machine torch assembly with 7.6 m (25') lead
	059483	Duramax 180° mini machine torch assembly with 10.7 m (35') lead
	059484	Duramax 180° mini machine torch assembly with 15.2 m (50') lead
3	228735	Kit: Duramax 180°/Duramax 180° mini torch front mounting sleeve
4	228736	Kit: Duramax 180°/Duramax 180° mini torch adapter ring (coupler)
5	228716	Kit: Duramax 180°/Duramax 180° mini torch main body replacement
6	228720	Kit: Cap-sensor switch replacement
7	058519	O-ring
8	075504	Pilot terminal screw
9	228730	Kit: Duramax 180°/Duramax 180° mini torch lead replacement, 4.5 m (15')
9	228731	Kit: Duramax 180°/Duramax 180° mini torch lead replacement, 7.6 m (25')
9	228732	Kit: Duramax 180°/Duramax 180° mini torch lead replacement, 10.7 m (35')
9	228733	Kit: Duramax 180°/Duramax 180° mini torch lead replacement, 15.2 m (50')
9	228734	Kit: Duramax 180°/Duramax 180° mini torch lead replacement, 22.8 m (75')
	128650	Remote start pendant for machine torch, 7.6 m (25')
	128651	Remote start pendant for machine torch, 15.2 m (50')
	128652	Remote start pendant for machine torch, 22.8 m (75')
	223035	Kit: 85 A Work lead with hand clamp, 7.6 m (25')

¹Other work lead options available.

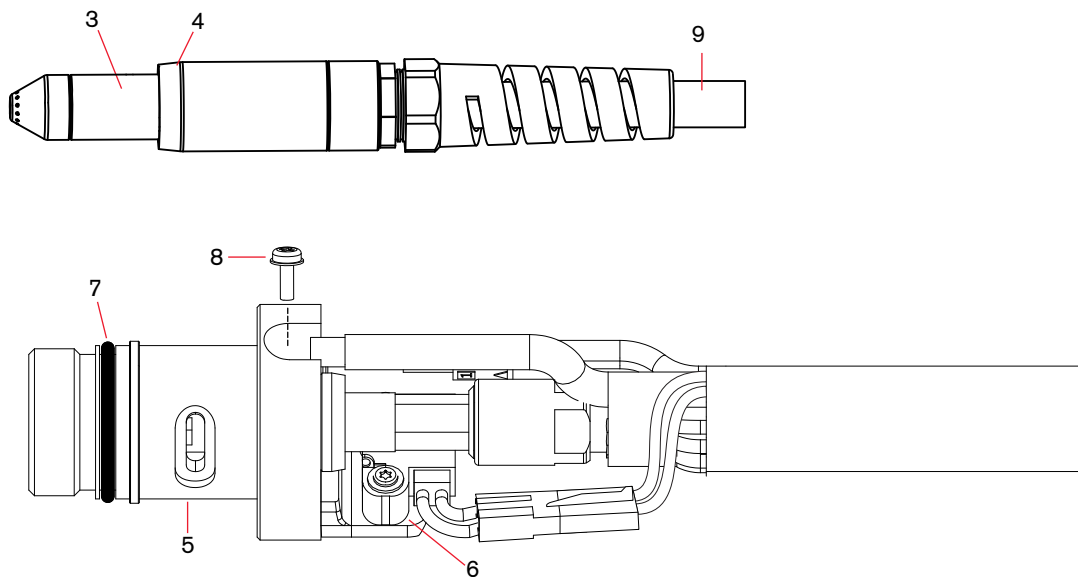

See pages 50–51 for current system part number information.